

Schwing Concrete Pumps

SP 1000 / SP 1200 / SP 1300 / SP 1400



Schwing Concrete Pumps

Introducing the Schwing range of concrete pumps designed to meet the demands of various entry level concrete pumping jobs. These pumps are designed to maximise your productivity with lowest operating costs.

RL Rock

Made after years of extensive study in the behaviour of tough concrete mixes, this valve is ideally suited for pumping harsh concrete and can withstand rugged site conditions as in India. This valve has been recognised worldwide as the toughest concrete valve. The optional hard-facing is also recommended.



RL Rock Valve

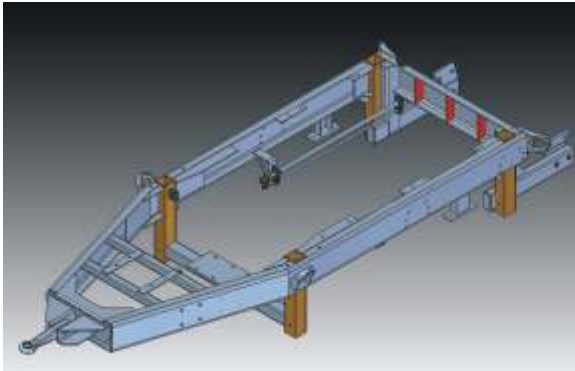

Specially designed rigid chassis

Rigid Chassis

Strengthened Chassis with shock-resistant stabilisers to increase strength and stability.

Portability

The conveniently placed towing hook and toughened frame and axle enable portability across rough terrain. The low weight of the pump allows it to quickly move it from one site to the other.

Hydraulics

Direct high-torque driven on to the agitator shaft as well as robust design of all hydraulic components in conjunction with constant flow micro-filtering of the hydraulic oil ensure operational reliability and a long service life.



Gearbox drive for agitator

Easy maintenance

The easy access to all the parts of the machine ensures that maintenance requires the minimum time for maintenance so your machine is up and running in no time at all.



Integrated control block



10m remote comes as a standard

Control

An easy to use remote with 10m cable comes as standard with the pump so your operators learn and start using it immediately. The famous Schwing maintenance-free control system with its proven free flow hydraulics ensures optimum fuel consumption, low heat generation and helps your components last long to reduce your operating costs.



Gear Box for agitator motor

By controlling the drive of the agitator motor through a gearbox, there is lesser damage on the agitator and lesser stress on the hydraulic components leading to increased life of the product.

Pumping

The pump has two powerful differential and pumping cylinders. The prodigious combined capacity and performance of these cylinder systems ensures a high output. Our pumps are designed to offer you maximum output with minimum number of strokes to increase the life of the cylinders.



SP1000



SP1200



SP1300



SP1400

TECHNICAL DATA

Parameters	Unit	SP 1000	SP 1200 D / E	SP 1300	SP 1400 D / E	
Engine / Motor Capacity	kW	35	48.6 / 45	48.6	48.6 / 45	
Nominal speed	min ⁻¹	2100	2100 / 1500	2100	2100 / 1500	
Pumping Cylinder Ø x Stroke	mm	180 x 1000	180 x 1200	150 x 1200	180 x 1400	
Differential cylinder drive		Piston side	Rod side	Rod side	Piston Side	Rod side
Max. No. of Strokes per min		24	24 / 21	29	16 / 12	24 / 21
Max. theor. Concrete Output	m ³ /h	36	45 / 38	37	34 / 25	52 / 40
Max. Concrete pressure	bar	65	70	85	99	63
Capacity of Charging Hopper	litres	400	400	400	400	
Dead Weight incl. oil and Fuel	kg	3560	3800	3800	4500	
Delivery line Ø up to	mm	150	150	150	150	

SCHWING - STETTER

ALWAYS CLOSE TO THE CUSTOMER.



- Sales Branch
- Resident Engineer
- Resident Engineer with Spares Depot
- Service Centre with Spares Depot
- Dealership Support
- Customer Training Center

SCHWING STETTER (INDIA) PVT LTD

An ISO 9001 : 2008 Company

CORPORATE OFFICE : F 71 - 72, SIPCOT Industrial Park, Irungattukottai, Sriperumpudur Taluk, Kancheepuram District, Tamil Nadu - 602105.
Tel : 044 2715 6780 / 781, 47108100
Fax : 044 2715 6539 Email : schwing@vsnl.com

Mumbai : 620/621, Nirmal Lifestyle Corporate Centre, 6th floor, LBS Marg, Mulund (West), Mumbai 400080.
Tel : 022 25624863 / 64, 30718300
Fax : 022 25624865 / 66
E-Mail : mumbai@schwingstetterindia.com

New Delhi : 9, Okhla Industrial Estate, Phase III, New Delhi - 110 020.
Tel : 011 30928500 Fax : 011 30928530
E-Mail : newdelhi@schwingstetterindia.com

Kolkata : Y6, Block EP, Sector V, Electronics Complex, Salt Lake City, Kolkata-700091.
Tel : 033 3322 3300 / 3355 5588 Fax : 033 33223326
E-Mail : kolkata@schwingstetterindia.com

Hyderabad : Door No-8-2-268/1/C Plot No.2, Road No-3, Aurora Colony, Banjara Hills, Hyderabad-500034.
Tel : 040-33555588 / 30948601 Fax: 040 23731770
E-Mail : hyderabad@schwingstetterindia.com

Vizag : Plot No.54, IDA - Block 'D', Expansion, Auto nagar, Vissakhapatnam - 530 012
Tel : 0891 6461783 Fax: 0891 2706063

Bangalore : No 138-B, "UDAYAGIRI COMPLEX", 3rd Phase, KIADB Industrial area, Peenya, Bangalore 560058.
Tel : 080 3355 5588 Fax : 080 3011 4301
E-Mail : bangalore@schwingstetterindia.com

Mohali : D 91-PH-VII, Industrial Area, Mohali, Punjab - 160 055.
Tel : 0172-3957500 / 3957501 / 3957503
E-Mail : chandigarh@schwingstetterindia.com

Jamshedpur : C/o. Akka Garden Marriage Hall Road No.17, Purulia High Way, Near Chepa Pul, Azad Nagar Mango, Jamshedpur-832 110.
Tel : 0657-236 0003

Ahmedabad : 103, Shivalik Arcade, 100 Ft.T.P Anand Nagar Satellite Road, Satellite, Ahmedabad 380 051.
Tel : 079- 3355 5588 Fax : 079-4006 4084
E-Mail : ahmedabad@schwingstetterindia.com

Cochin : No.34 / 1404 B, Arakkakadavu Road, Anchumana, Edappally - PO. Kochin - 682 024
Tel : 0484 - 3355558 / 2349858 Fax : 0484 - 4055984
E-Mail : cochin@schwingstetterindia.com

Raipur : NH-6, Opposite Vardhaman Motor, Kumahari, Dist - Durg, Chhattisgarh - 490042.
Tel : 07821 247066
E-Mail : sunil.kumar@schwingstetterindia.com

Pune : Arihant Court, Shop No. 1,2 & 3, 481, Rasta Peth, Mudliar Road, Pune 411 011.
Tel : 020-33555588 Fax : 020-30531517, 30531511
E-Mail : pune@schwingstetterindia.com

Coimbatore : No:2005, Trichy Road, Old Rajalaxmi Mills, Singanallur, Coimbatore -641005.
Tel. : +91 422 - 3223660
E-Mail : coimbatore@schwingstetterindia.com

Mangalore : Door No.4/24/9, Off Survey No.165/1A, "Shreya Towers" Surathkal, Mangalore- 575 014
Tel : 0824 - 3200381 Fax: 0824 - 2478381

Patna : C/o. Mrs. Hemanti Devi, East Pahari, NH-31, Near Zero Mile, Patna - 800007.
Tel: 0612-3057728 Fax : 0612-3057725
E-Mail : shashi.kant@schwingstetterindia.com

Surat : C-19 & D-19 Green Park, Light Industrial Estate, Opp. Madhav Park, Udhna Navsari Road, Unn - Surat -395023. Tel : 0261 2750033
E-Mail : ahmedabad@schwingstetterindia.com

Guwahati : House No. 161, Jaya Nagar, Six Miles, Khanapara, Guwahati 781 022.
Tel: 0361 2234738 / 9957566738

Bhubaneswar : Plot No:182, Naharkanta, Rudrapur, Beside Puri Main Canal, NH5, Bhubaneswar - 752101. Odisha. Tel : 0674 2463999

Indore : Godown no.20, Pipliya Kumar Mangal Compound, Dewas Naka, MR-11 Indore - 452010, M.P. Tel : 0731-2909911
E Mail : ahmedabad@schwingstetterindia.com